

Platform Overview

AheesaTM **SEAL** is a smart electronic lock designed to provide **touchless, hygienic, and secure access** through encrypted Bluetooth authentication. Users can unlock doors using their smartphones without touching keypads, handles, or buttons—reducing exposure to frequently touched surfaces and improving personal safety.

Powered by a **RISC-V 32-bit secure processor**, SEAL ensures trusted operation through **secure boot**, encrypted firmware, and authenticated communication protocols. The lock operates efficiently using a **low-power design** and supports both **rechargeable battery** operation and wired power input, enabling flexible deployment across homes, offices, commercial buildings, and shared access environments.

The platform consists of:

- Smart Lock Hardware
- Secure Embedded Firmware
- Mobile Application for Access Control

System Architecture

AheesaTM **SEAL** is built as a **layered secure access platform**, where each subsystem plays a defined role in access control, security enforcement, and power efficiency.

1. Hardware Layer

- RISC-V 32-bit Processor
- Bluetooth Low Energy (BLE) Radio Module (FCC compliant)
- Motor / Actuator Driver circuitry
- Power Management (Rechargeable battery + optional wired supply)
- Onboard Status Indicators

2. Embedded Firmware Layer

- Secure Boot process ensures only authenticated firmware executes
- Key Management with protected key handling
- BLE Security Stack implementing secure pairing and replay protection
- Access authorization logic for validating user commands

3. Communication & SDK Layer

- BLE communication APIs for device discovery and control
- Authentication and secure session operation
- Android / iOS SDK compatibility
- Supports standalone and integrated system deployments

4. Application Layer

- User Enrollment & Role Assignment
- Proximity Unlock & Manual Unlock Controls
- Access Logs & Event Monitoring
- Guest / Temporary Access Scheduling

Block Diagram

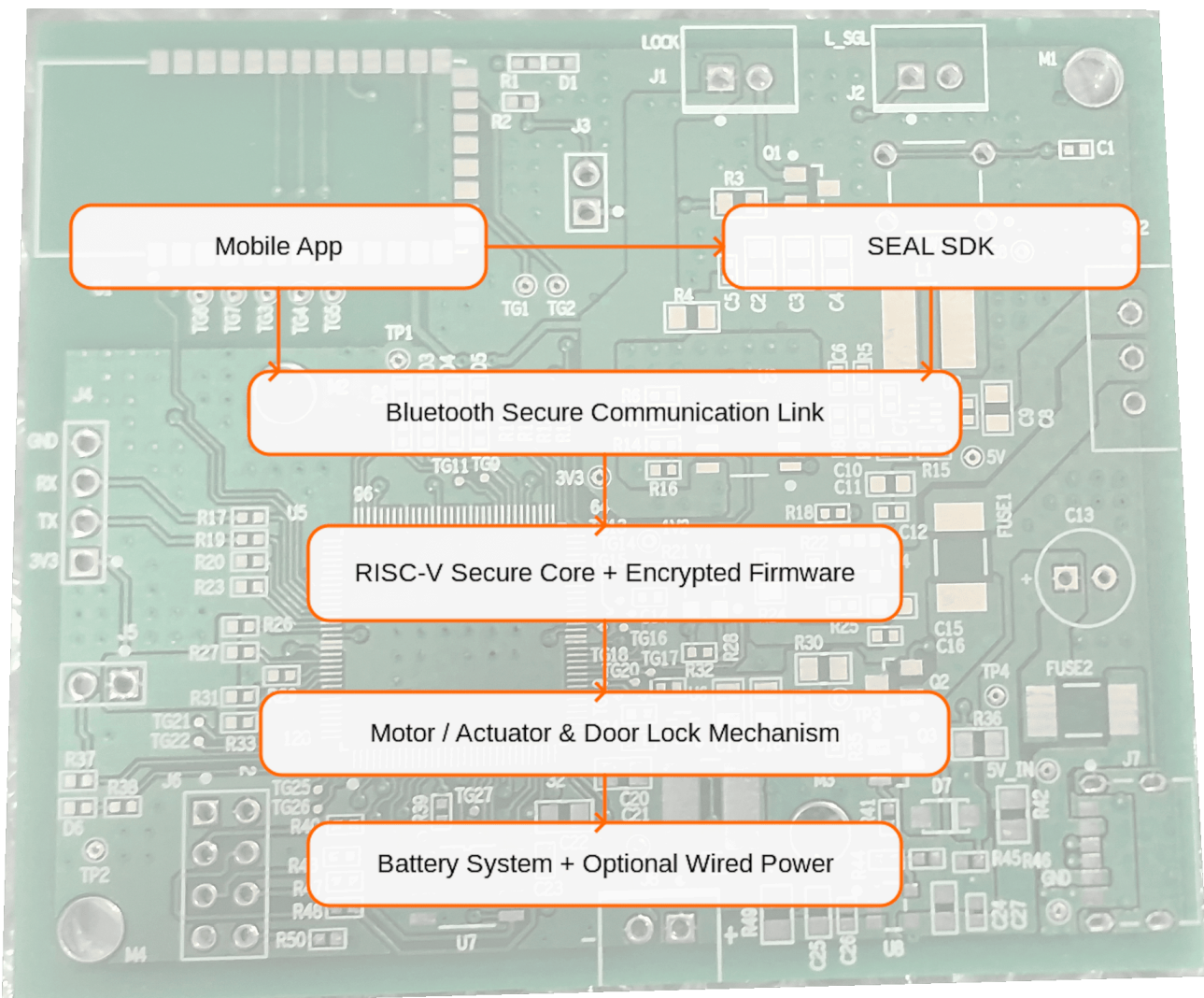

Key Advantages

- **Touchless Entry** Reduces Exposure to Shared Surfaces
- **Hardware-Based Security** Rooted in a RISC-V Secure Core
- **Flexible Power Options** for Deployments Across Environments
- **Customizable** and Supports Multi-User and Managed Access Scenarios
- Complete Smart Lock Ecosystem (Hardware + Firmware + App)

Regulatory & Compliance

- FCC Part 15 compliant Bluetooth Low Energy (BLE) module
- RoHS compliant hardware design
- Designed to align with international RF exposure and safety standards

Use Cases

- Residential Homes & Apartments
- Office and Workplace Access
- Clinical and Laboratory Facilities
- Shared Living and Co-Living Spaces
- Hospitality, Short-Stay, and Managed Rental Environments

About AheesaTM

AheesaTM is a **fabless semiconductor** and **embedded systems** company focused on secure, intelligent access technologies. We design hardware, firmware, and platforms that emphasize reliability, security, and real-world usability for modern connected environments.

Ordering Information

For product inquiries, evaluation units, integration support, or volume quotations, please contact our sales team.

Email: sales@iheesa.com